

## LEAVING CERT ENGINEERING - WELDING NOTES

Welding is a fabrication process that joins materials, usually metals. This is often done by melting the work-pieces and adding a filler material to form a pool of molten material that cools to become a strong joint, but sometimes pressure is used in conjunction with heat, or by itself, to produce the weld. There are eight welding processes which are divided into three categories shown below.

### Electric

- Electric Arc - MMA (manual metal arc)
- MIG (metal inert gas)
- TIG (tungsten inert gas)
- Submerged Arc
- Electro-Slag



### Resistance

- Spot
- Seam

### Gas

- Oxy-Acetylene

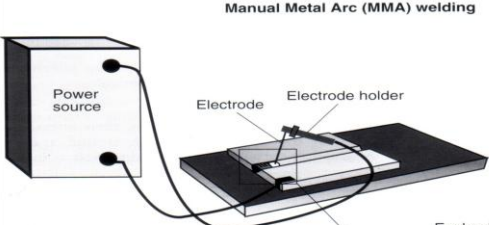
### ELECTRIC ARC WELDING

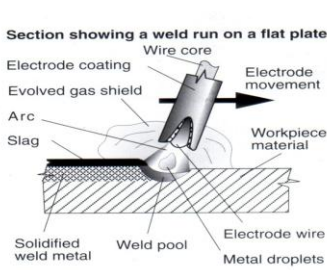
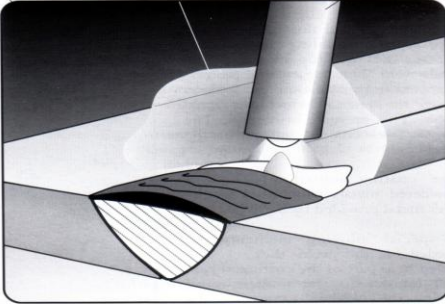
<p style="text-align: center;"><b>Manual Metal Arc (MMA) welding</b></p>   <p style="text-align: center;"><b>Section showing a weld run on a flat plate</b></p>  	<p><b>Operation of the electrode</b></p> <p>The weld pool is protected from oxidation by the gasses produced by melting the chemicals on the electrode coating.</p> <p>This wire electrode also acts as a filler material to fill the gap between the two parts being joined.</p> <p>Its third function is to form a slag which protects the weld area from cracking as it allows the joint cool slowly and protect it from oxidation.</p>
<p><b>Principle of operation</b></p> <p>Electricity is passed through an electrode which jumps between the electrode and the work piece. This causes an arc which produces great heat melting the electrode and the work piece causing the edges to fuse together. (consumable electrode.)</p>	<p><b>Applications</b></p> <p>This has many operational uses such as repair work to constructional steel. It is ideal for outdoor uses as the gasses needed to form the shield are not blown away.</p>

## MIG WELDING

	<p><b>Operation</b></p> <p>MIG uses an inert gas such as Argon or CO<sub>2</sub> to shield the weld</p> <p>The bare wire electrode is fed continuously to the weld - semi-automatic process</p> <p>Can be used on light and heavy plate.</p> <p>Does not produce a slag and can be used for multi run welds and by robots.</p>
<p><b>Principle of operation</b></p> <p>Electricity is passed through an electrode which jumps between the electrode and the work piece. The electrode is touched briefly against the work, this causes an arc which produces great heat melting the electrode and the work piece causing the edges to fuse together.</p>	<p><b>Applications</b></p> <p>This is one of the most common ways of welding. It can be used to weld sheet metal as well as heavy plates. As the electrode is fed automatically and no slag is formed it is ideal for robotic welding for example car production.</p>

## TIG WELDING

	<p><b>Operation</b></p> <p>The arc melts the two edges to be joined as well as the filler rod forming the weld pool.</p> <p>Gas is pumped through the nozzle protecting the weld pool from oxidation.</p> <p>The electrode is only to maintain the arc supplying the heat. A consumable filler rod fed by the operator gives the extra metal necessary for the weld pool.</p>
<p><b>Principle of operation</b></p> <p>Two separate currents flow in the circuit in this welding process. One is for the arc and is similar to MAGS, the other is a high frequency current used to start the arc. This means an arc is not stuck by touching the work piece as before.</p>	<p><b>Applications</b></p> <p>TIG is suitable for welding most metals. However, when welding aluminium AC is used. This is necessary to breakdown the oxide layer on the outside of the aluminium which has a high melting point. It is also suitable for stainless steel.</p>

## SUBMERGED ARC

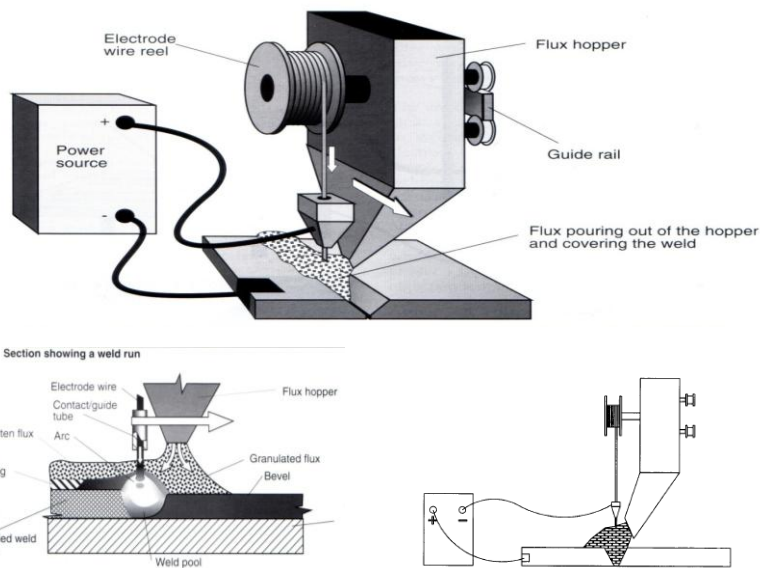

### Operation

The arc melts the two edges to be joined as well as the electrode forming the weld pool.

The arc is submerged by a granulated flux released from a hopper ahead of it. This flux melts with the heat of the arc protecting the weld pool and forming a slag that controls cooling.

### Applications

This is an ideal automated welding process. It is ideal for long continuous welds and for shipbuilding.

### Principle of operation

Electricity is passed through an electrode which jumps between the electrode and the work piece. The arc produces great heat melting the electrode and the work piece causing the edges to fuse together. The electrode is a wire fed consumable.

## ELECTRO-SLAG

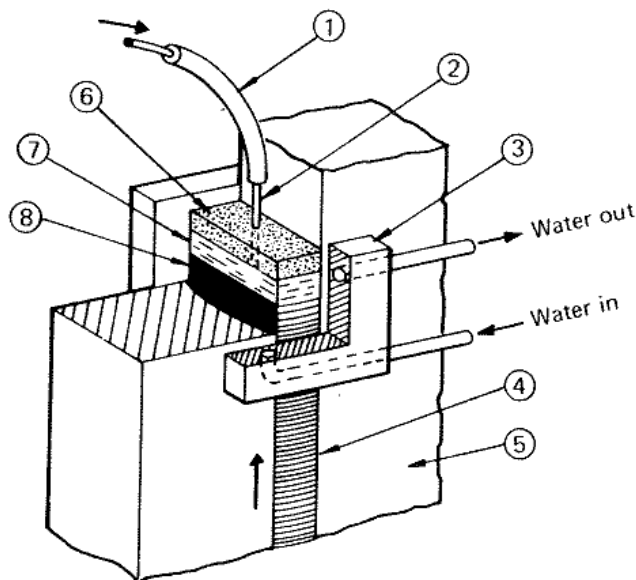

### Operation

Two pieces of metal are placed between the electrodes.

The electrodes are then closed on the piece causing the circuit to complete.

The resistance in the metal between the electrodes causing them to melt and fuse together.

### Applications

This is generally used to join very thick plates together giving a series of overlapping welds until the two plates are fully joined. It is suitable for automatic welding as it is used on large plates usually.

### Principle of operation

Electricity is passed between two couples on either side of the plates. This causes the materials in the gap to melt as well as the edges of the plates. This form the weld pool.

## SPOT WELDING

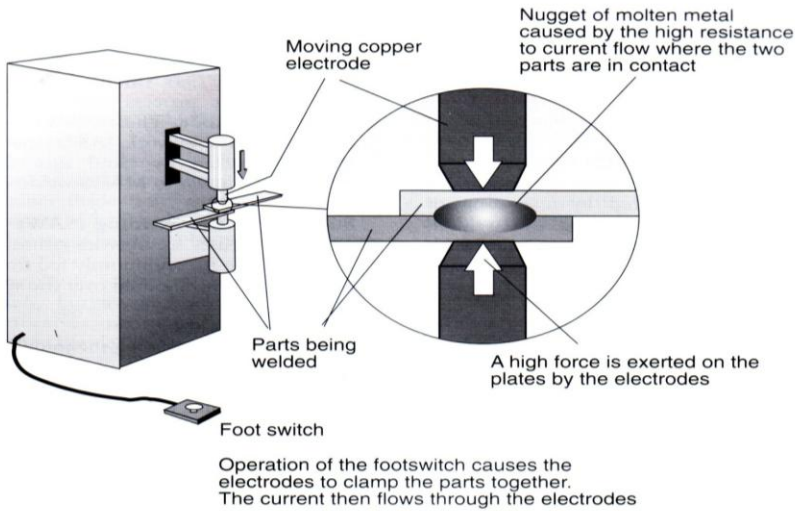
 <p>Operation of the footswitch causes the electrodes to clamp the parts together. The current then flows through the electrodes</p>	<p><b>Operation</b></p> <p>Two pieces of metal are placed between the electrodes.</p> <p>The electrodes are then closed on the piece causing the circuit to complete.</p> <p>The combination of heat and pressure allows the metals to be fused together.</p> <p>It is recognised by the distinctive circular mark left at the site of the weld.</p>
<p><b>Principle of operation</b></p> <p>Electricity is passed between two electrodes with the pieces to be joined in between. As the electricity passes through the material the resistance of the metals cause the metals to melt fusing them together.</p>	<p><b>Applications</b></p> <p>This is generally used to join light gauge steel sheet metal such as filing cabinets and car body panels. Sheets that are too thick will prevent the current from flowing and will not work</p>

## SEAM WELDING

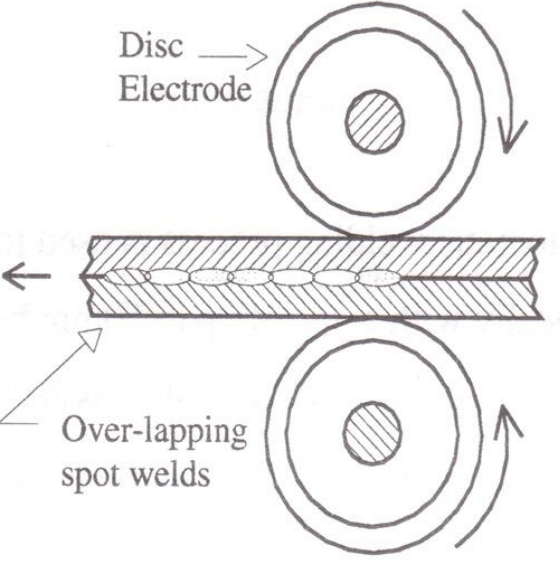
	<p><b>Operation</b></p> <p>The work-piece is moved between the rollers and pulses of current are supplied. Each pulse is set to last long enough to produce a spot weld.</p>
<p><b>Principle of operation</b></p> <p>A form of resistance welding that uses copper roller electrodes to provide a continuous run of overlapping spot welds as the current is activated at set intervals. One of the electrodes may be driven by an electric motor.</p>	<p><b>Applications</b></p> <p>This is generally used to join light gauge steel sheet metal similarly to spot welding, but are more suitable to longer runs.</p>

# OXY-ACETYLENE

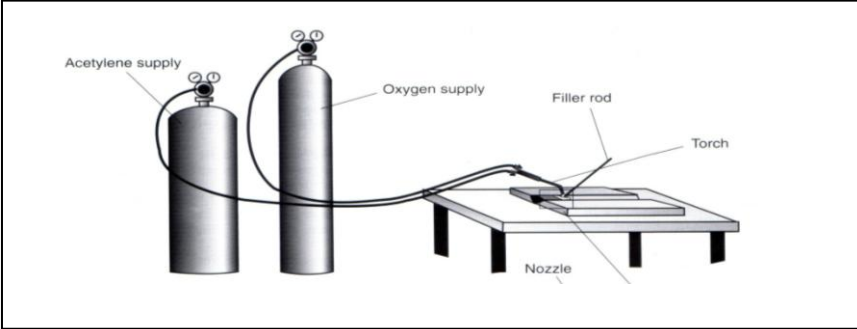

**Principle of operation**

A fusion welding process, heat is concentrated on the joint edges until the metal melts and starts to flow.

The molten metal fuses as the joining edges meet.

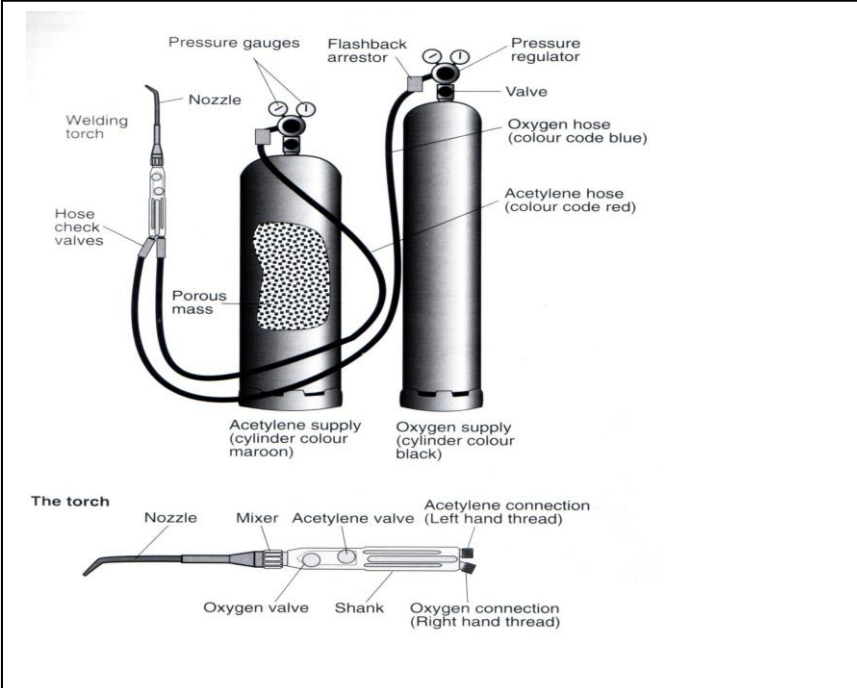

**Operation**

Oxygen and acetylene gas are burned at the tip of the nozzle on the welding torch.

Oxidation of the joint faces is prevented by an envelope made up of the products of combustion.

A filler metal, in rod form, can be added.

**Storage**

Acetylene is dissolved in a porous material called acetone, which will absorb 25 times its own volume of Acetylene. Acetylene would explode if it were stored under pressure.

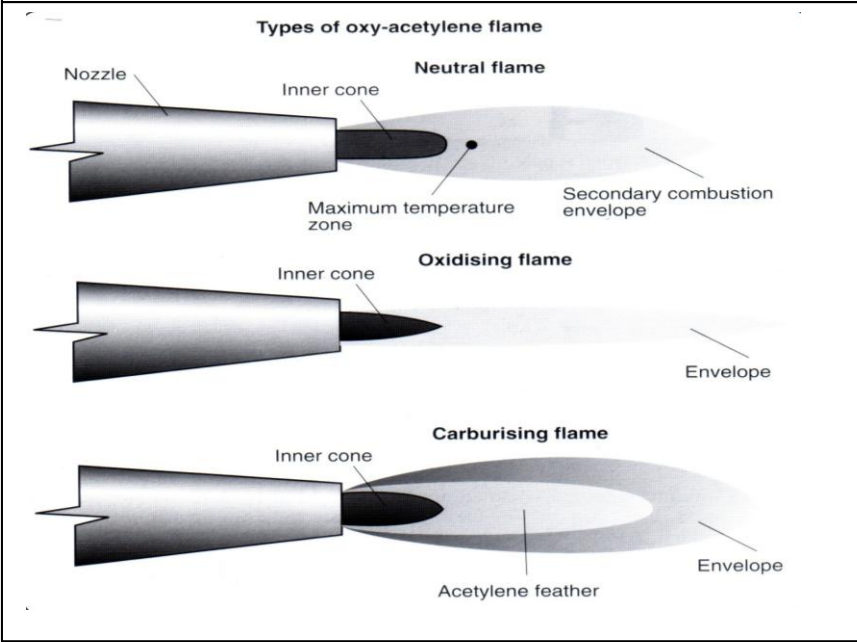

**Applications**

**Neutral flame** – Fusion welding of steel and cast iron.

**Oxidising flame** - Used to weld copper and brass.

**Carburing flame** - Used to weld aluminium and alloy steel